

**DO NOT SCALE
IF IN DOUBT ASK**

Window Detail
(Type 1)

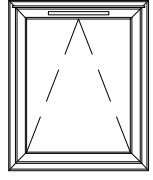

Size = 925mm x 1125mm
White UPVC Frame
Double Glazed
4000mm² Trickle Vent
Restrictor Stays
Lockable Handles

Basin Sizes	450mm Wide
Basin Rim Height	800mm (Adult)
Toilet Rim Height	390mm (Adult)
Urinal Lip Height	610mm (Adult)
Disabled Sanitaryware Heights/Sizes	To Part M Of The Building Regulations
Kitchen Sink/Worktop Height (to top)	See Drawing
Tap Types	Lever
Basin Water Temperature	43°
Sink Water Temperature	60°
Splashbacks to basins & sinks	White ceramic tiles
Internal Partitioning To Give A Weighted Sound Reduction Of 38dB (Estimated). Partitioning Constructed From Timber Studding Lined With 12.5mm Plasterboard.	
Internal Door Finish	Light Oak
Internal Door Furniture Finish	Ebony
Door Furniture Height (Handles, Dig Locks Etc.)	Not To Be Fitted Over 1200mm Above FFL
Fire Resistance Of External Walls (In To Out)	Half Hour
Internal Lining Of Perimeter Walls	12.5mm Plasterboard
Vented Plastisol Steel Vermin Skirt (Max 600mm High)	Extra Over
Roof Type	Steel
Module Column Heights	3230mm
Fascia Type	Standard (500mm Deep)
Ceiling Type	Fixed
Ceiling Height	2500mm
FFL From Top Of Foundations	325mm
Uniformly Distributed Floor Load	3kN/m ²
Additional Notes	

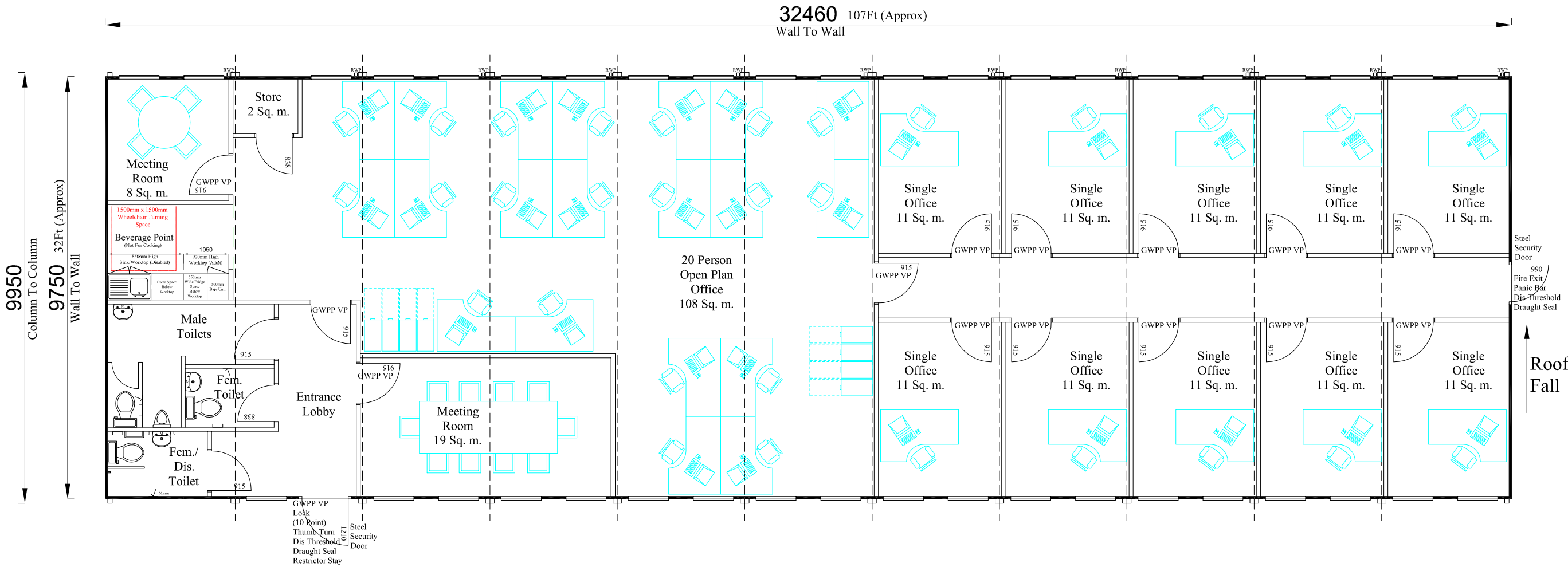

NOTES:
All dimensions must be checked on site and not scaled from this drawing

Sq. m. Area = 315
Sq. Ft. Area = 3393

Building Design/Position On Site All Subject To Full Site Survey And Building Control Approval

Any loose furniture shown is indicative (by others)

Toilet Provision Note

The Number Of Toilets Shown Are Adequate For The Following Numbers Of People:

Male - Up to 15

Female - Up to 15 (incl. 5 disabled)

From BS 6465-1:2006

© copyright



Relocatable Building Systems

Catfoss Lane, Brandesburton, Driffield, East Yorkshire, YO25 8EJ
Telephone : 01964 544344 Fax : 01964 542141
E-mail : sales@foremansbuildings.co.uk
Web : http://www.foremansbuildings.co.uk

CLIENT
A Client

JOB TITLE
11 Bays Of Portakabin Duplex Modular Building 32Ft x 10Ft Bays

DRAWING TITLE
Proposed Layout Plan For 30 Person Office With Single Offices

SCALE
1:100

DATE
30/03/2009

DRAWN BY
R. COUSINS

DRAWING NUMBER
Standard Layouts/Offices/32Ft/
30 Person With Single Offices

REV